

Township of Lower Merion
EMERGENCY
Police—Fire—Ambulance
Dial 9-1-1

or
610-642-4200



NON-EMERGENCY NUMBERS:

Police: 610-649-1000

Fire: 610-645-6190



Printed on recycled paper
c. 2010 Lower Merion Police Department

BURGLARY PREVENTION:



YOUR BEST HOME INSURANCE

A publication of the Township of Lower Merion
POLICE DEPARTMENT

71 E. Lancaster Avenue
Ardmore, PA 19003-2323
610-649-1000

WARNING

One window in every bedroom on the ground floor and second floor must be available as a fire exit, particularly for children and guests in your home. At night, the bedroom window may often be the quickest and safest means of getting out.

Because of the danger of fire, decorative iron grills are **not recommended** on bedroom windows.

GRATES AND GRILLS FOR PROTECTION

Grates and grills offer protection for ground level entrances, especially for basement windows which cannot be seen from the street or by neighbors.

Alarms offer additional security but should never be substituted for good locks. There are many types of alarms on the market. Secure the services of a reputable alarm company and insist on U.L. listed equipment. **A good alarm system should include, but not be limited to:**

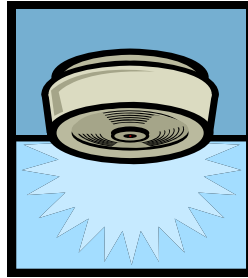

1. A battery fail-safe back-up
2. Fire-sensing capability
3. Read-out ability to check status of system sensors
4. A local sounding device
5. Ability to notify police through a central station or by automatic dialer
6. Warning decals

For further assistance and information on alarm systems, contact the Lower Merion Police Department's Crime Prevention Unit at 610-645-6240.

If you follow the recommendations in this booklet, the possibility of a crime occurring at your premises will be reduced. However, this booklet is NOT intended to "Burglar-Proof", "Robbery-Proof" or "Theft-Proof" your home.

TABLE OF CONTENTS

Know Your Burglar	4
Vacant House Program	5
Tips for When Out of Town	6 - 7
Nosy Neighbors and Barking Dogs	8
Always Avoid Danger	9
Doors	10
Sliding Doors	11
Latches	12
Types of Latches and Locks	13
Locks: The Key to Security	14
Other Locking Devices	15
Padlocks	16
Windows	17
Grates, Grills and Alarms	18
Notes	19

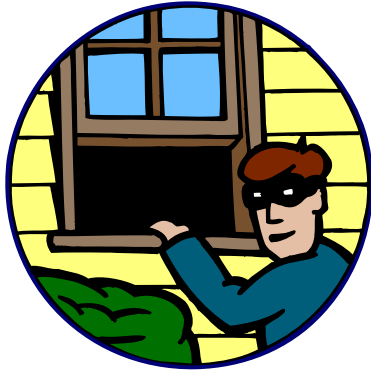

1. KNOW YOUR BURGLAR.

Burglars are *not* the highly skilled and calculating persons you may think they are. **Most are unskilled and select their victim at random** when the opportunity presents itself.

Many burglars gain entry by an unlocked door or

window, or by defeating an inferior or poorly installed locking device.

Most burglaries occur during daylight hours, usually between 9:30 a.m. and 3:30 p.m. when homes are often vacant. Many burglars, however, strike in the early evening hours when residents are away from home. Burglaries occurring between midnight and 6 a.m. are less frequent, but these burglaries are most dangerous to the victims, because the likelihood of confrontation increases.

Many burglars cruise a neighborhood looking for easy pickings, often knocking on doors to determine if an owner is absent. They attempt to gain entry by various pretenses to appraise a home for valuables. Be suspicious; don't admit strangers to your home. **REDUCE THE BURGLAR'S OPPORTUNITY.**

2. DISCOURAGE THE BURGLAR FROM CHOOSING YOU.

If a burglar believes he will obtain the same results by entering your home as your neighbor's, but the entry will require less force and entail less chance of apprehension, he will choose your home. **Make your home appear difficult to enter** so that you are less likely to be singled out for attack. An occupied look will discourage most burglars.

WINDOWS

The primary interest in securing windows is to keep a burglar from entering by prying a window open. Most burglars avoid breaking glass, because they fear attracting attention.

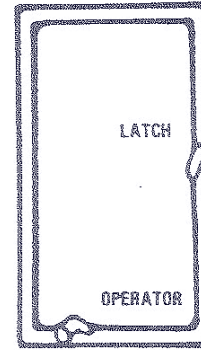

CASEMENT WINDOW

CASEMENT WINDOWS

These are the simplest to secure. Make sure the latch works properly and that the "operator" has no excess play. Replace worn hardware. Key locks are also available for casement windows.

SLIDING WINDOWS

Sliding windows may be secured by the same methods recommended for sliding doors.

LOUVRE WINDOWS

Louvre windows are bad security risks. Remove and replace them with solid glass or other ventilating windows.

DOUBLE HUNG WINDOWS

For double hung windows, drill a downward sloping hole into the top of the bottom window through and into the top window, and insert a pin or nail. The pin or nail should not go completely through both windows. Leave the head of nail or pin slightly exposed so that it can be easily removed in an emergency.

For ventilation with a secure window, lift the lower panel 5-6" and drill additional holes through the existing lower frame holes into the upper frame. This allows the placement of the pins or nails through both frames while the window is 5-6" open, but prevents the window from being opened to an extent that would allow entry. Key locks are also available for these windows from hardware stores or locksmiths.



PADLOCKS

There are many padlocks on the market. The following descriptions, which you can take to the locksmith or hardware store, is the minimum standard for an exterior padlock:

1. Hardened steel, 9/32" shackle.
2. Double locking mechanism-heel and toe.
3. Five-pin tumbler.
4. A key-retaining feature, if possible. This prevents removing the key until you have locked the padlock.

NEVER LEAVE YOUR PADLOCK

UNLOCKED. This is an invitation to have the padlock removed, so that a key can be made and the lock returned to its position. Later the burglar returns when no one is home and enters at his leisure, using HIS key.

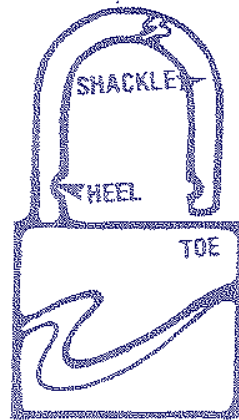

GARAGES

The single lock on the garage door is inadequate to keep intruders from prying up the opposite side and crawling in.

1. Add another bolt and padlock to the opposite side.
2. Install a pair of cane bolts to the inside. (Note that these are operable only from the inside).
3. Add a top center hasp, as illustrated. Any person of average height can operate this locking device.

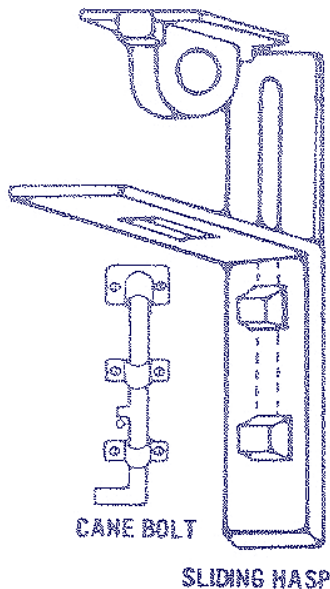

3. DON'T BRING ATTENTION TO YOURSELF. BE CAUTIOUS IN CONVERSATION.

Many burglars depend on information supplied by unwitting victims or others who have information about a particular home or family. **Be friendly but suspicious** about your personal or financial situation. Do not post absence from your home on social networking sites. **PLAY IT SAFE** and **DON'T ADVERTISE YOUR HOME AS A GOOD PLACE TO BURGLARIZE.**

4. DON'T TELL A BURGLAR WHEN AND WHERE TO STRIKE.

Classified advertising, social event announcements and obituaries often tell a burglar when and where to strike. Avoid the use of addresses in classified advertising, announce social events after the fact, and leave a house-sitter when attending funerals.

When going away for any length of time, contact the Lower Merion Police Department at 610-649-1000 and ask to be placed in our **"Vacant House Program."** An officer will periodically check that your home remains secure.

5. PROTECT YOUR KEYS AND LOCKS.

Always separate car and house keys when you leave your car on a lot or in a garage where keys must also be left. It is easy for an attendant to make a duplicate of your residence key and obtain your address from your license number.

Don't give keys to workmen regardless of how long they will be working in your home. Ask a neighbor to let them in and then re-lock your home in your absence.

Never leave keys under mats, in the mailbox, or on a ledge above your door. Burglars know all the hiding places.

Don't leave identification on your key ring. If it is lost

the finder will be able to trace it to your home. If a key is lost and there is a chance the finder will know where you live, change the lock tumblers.

Always change exterior tumblers when you move into a new home. Throw away the old keys along with the worry about who might have duplicates.

6. DON'T LEAVE MESSAGES ON YOUR DOOR.

Messages left on your door tell a burglar that you're out and also when to expect your return. Ask friends not to leave notes on your door and pay them the same courtesy.

7. DON'T LET A SMALL MAILBOX GIVE YOU AWAY.



If the mailbox is overflowing, there's a good chance you're out. Burglars know this. Get a mailbox large enough to hold an entire day's mail. Mail slots in your door offer even better protection. Stop mail service at your Post Office or have a friend or neighbor retrieve your mail.

8. KEEP YOUR GARAGE DOOR CLOSED.

An empty garage means someone's not at home. Keep the garage door closed and cover garage windows to keep the burglar guessing.

9. DON'T LET PACKAGES GIVE YOU AWAY.

Don't have merchandise delivered when you're not home. A package on your doorstep is an invitation to a petty thief and a sign to a burglar that you're out. Advertisements hanging on your door are also giveaways. Ask a neighbor to remove them until you return.

10. GIVE YOUR HOUSE A LIVED IN LOOK WHEN YOU'RE GOING TO BE OUT OF TOWN.

Have a friend shovel the snow, rake the leaves and cut the

pried open if securely mounted on the door frame.

CAUTION:: Because of the potential for fire or other emergency in your home, the use of a double cylinder lock may impede your ability to exit. If you install a double cylinder lock, a key should be left nearby. All family members and anyone in your home who may use these locks should know the key locations.

OTHER LOCKING DEVICES

CANE BOLTS

Many homes with pairs of doors have half-barrel slide bolts on the inactive doors. These are weak and inadequate. Cane bolts (1/2 inch in diameter by 12 inches high) installed at the top and bottom of the inactive door offer adequate security. A vertical "jimmy proof" rim lock installed on double doors offers additional security.

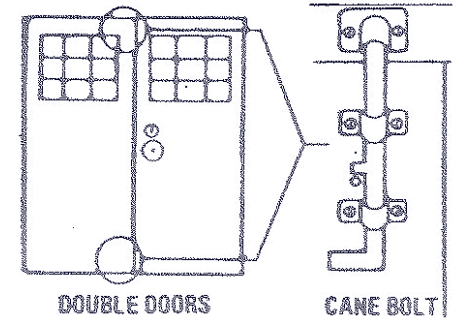

HINGING HASPS

Hinging hasps should be of hardened steel and installed with carriage bolts through the door or gate. Use large washes on the inside. After nuts are secured, deface the threads of the bolt ends with a hammer to keep the nuts from working off or being removed. The hasp should be installed so that when closed, all bolt heads are covered.

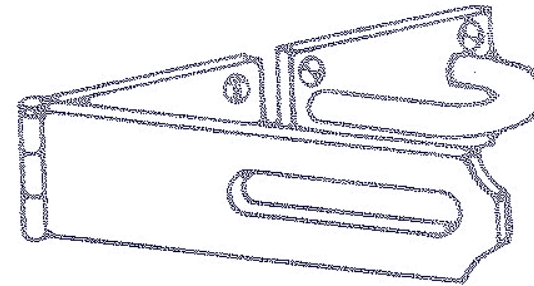

LOCKS: THE KEY TO SECURITY

COMBINATION MORTISED LOCKSET

Combination locksets found in many older homes offer adequate security for most residences; however, their use has declined because they cost more than knob latches, and it takes about four times longer to install them. Because of the labor cost involved, builders do not use combination locksets unless requested to do so.

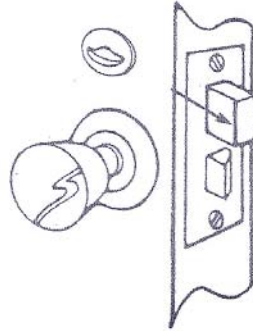

MORTISED DEADLOCKS

Auxiliary deadlocks mortised in solidly constructed doors offer good security. The lock throw (the length of the bolt when extended from the door) should be at least one inch. For solid doors, a single cylinder lock with inside thumb turn is sufficient; however, on doors with glass within 40 inches of the locking device, the glass shall be of tamper-resistant glazing material.

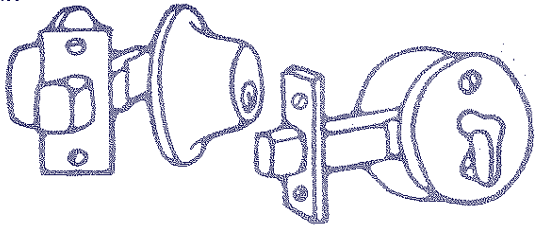

AUXILIARY RIM MOUNTED LOCKS

Good quality rim locks offer excellent security if properly installed on adequate doors. They are inexpensive and can be installed by the homeowner. These locks may be either single or double cylinder (double cylinder locks require a key to open from both sides) depending on the type of door to which they are attached, and are designed with either a horizontal or vertical bolt throw. The "jimmy proof" vertical-throw rim lock offers additional security because it cannot be

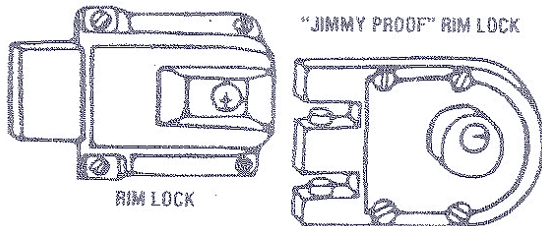

grass when you are away for long periods of time.

11. LEAVE AIR CONDITIONERS ON.

A closed up home on a hot day is a dead giveaway. Leave your air conditioner on when you're going out for a short while. The house will look occupied.

12. LEAVE THE LAWN SPRINKLER ON.

Use a water timer or leave the sprinkler on when you plan to be out for a short while. A lawn being watered gives a lived-in look.

13. HIDE YOUR GARBAGE CANS WHEN YOU'RE ON VACATION.

Empty garbage cans when others in the neighborhood have full cans is a tip to the burglar that no one's home. Put your garbage cans in your basement or storage shed while you're away, or ask a neighbor to use them occasionally.

14. LIGHT UP THE OUTSIDE.

Good exterior lighting is important, particularly when the yard area is obscured by high non-removable shrubbery. The best location for outside lights is under eaves. Inexpensive electric timers or electric photo-cells or passive infrared (motion detectors) sensors will automatically turn lights off and on.



15. USE ELECTRIC TIMERS FOR LIGHTS AND RADIOS.

Use enough timers to create a normal lighting pattern. A lonesome parlor or porch light invites trouble. **If only one light is left on, use the living room.** The illumination coming from this source is sufficient to silhouette an intruder through many windows in the home. It is also confusing to a burglar, who won't know whether you're away or at home asleep on the sofa.

16. MIX UP SHADES OR BLINDS.

Don't leave all blinds or shades in one position. Study them when you're at home and leave them that way when you leave. The best idea is to mix them up to give a lived-in appearance.

17. ASK YOUR NEIGHBOR TO BE NOSY.

Nosy neighbors scare away more burglars than police patrols. Ask your neighbors to watch your house in your absence. If they have a second car, ask them to park it in your driveway. Do the same for them.

18. DON'T GIVE AN INTRUDER A PLACE TO HIDE.

Shrubbery should never block the view of your front door. They should be kept trimmed to window sill level.

19. FRIGHTEN THE BURGLAR.

Burglars hate noise, and barking dogs frighten them quicker than almost anything else. It's the bark, not the dog's size, that counts in most instances.

20. PERSONALIZE YOUR PROPERTY.

Marked property is worthless to most burglars. Participate in your police department's Operation Identification. You can borrow a marking tool from your police department. Advertise the fact that your valuables are marked using decals furnished in the Operation Identification program.

21. PROTECT YOUR CREDIT CARDS.

Destroy useless credit cards and carry only those cards that you absolutely need while you're out. Keep a record of all card numbers and notify the company as soon as possible if a card is lost or stolen.



22. USE A SAFE DEPOSIT BOX.

Keep valuable papers, seldom used jewelry and coins, etc.

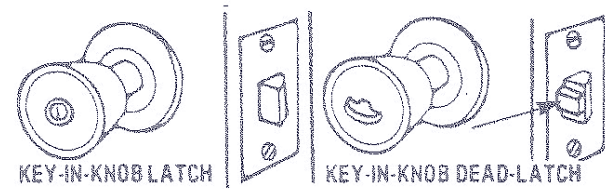

The primary difference in the two latches is the addition of a dead latch to

resist slipping of the latch with a plastic card. Additional security is recommended in the event your home is protected by either of these two devices.

NIGHT LATCHES

These are auxiliary rim (surface) mounted latches which are easily slipped, and therefore ineffective for security. The spring action and short beveled throw detract from their value as security devices.

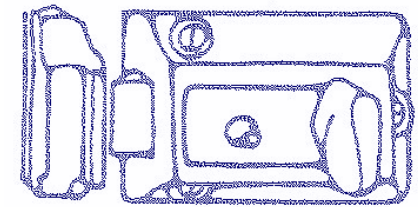

SKELETON KEY LOCKS

These tumbler skeleton key locks are still present in many older homes. They offer no security and should be supplemented by a quality deadlock.

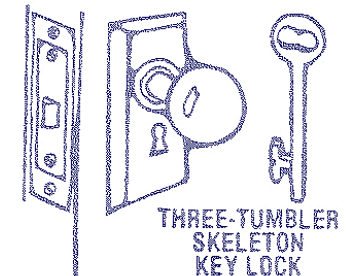

CHAIN LOCKS

Chain locks are usually ineffective as they are easily broken by a determined burglar. A wide angle viewer is more effective in answering the door when the caller is unknown. Viewers are inexpensive and easily installed. They offer additional security in that they keep the door between you and a stranger.

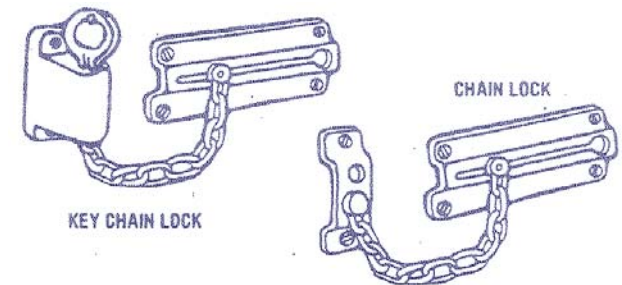

Many inexpensive commercial locks are available for this purpose including key locks obtained from hardware dealers or locksmiths.

Sticks and bars may be used to secure sliding doors but these are often removed by determined burglars. They offer no protection from the intruder making an easy exit with your property.

More recent models of metal "Charlie Bars" are available with the added protection of pins to prevent prying up from the outside through the space between the two doors.

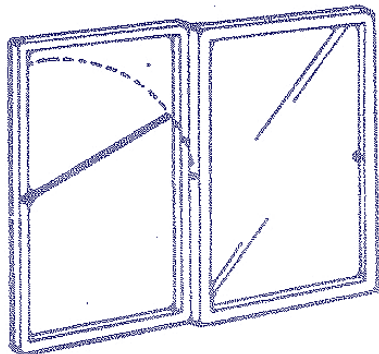

A sliding door may also be secured by the homeowner with very little effort at no cost. Simply drill a hole through the inside surface of the metal sliding door. A pin or nail may then be inserted through the frame and into the door to prevent it from being moved back or up and out of the track. The pin or nail must not pass completely through the door and outside frame or it may be knocked out from the outside.

CAUTION: Be certain that all family members as well as overnight guests know about the pin and its location so that they may open the door in an emergency.

LATCHES: THE BURGLAR'S FRIEND

KEY LATCHES

Most homes and apartments are built at a minimum possible cost with little consideration for the occupant's security. Most are equipped with key-in-knob door latches or key-in-knob dead latches, which although attractive, offer almost no security.

in a safe deposit box. That way, if your home is burglarized, the loss will be kept to a minimum.



23. DON'T GIVE THE BURGLAR THE TOOLS TO DO HIS JOB.

Keep ladders and tools where they belong—out of site and locked.

24. BE WARY OF STRANGERS.

If strangers in the neighborhood arouse your suspicions, notify the police. If you see a suspicious vehicle, jot down the tag number if possible. Note the description of any suspicious person so that you can aid police in the event he or she disappears before they arrive. **DO NOT** directly approach or challenge the stranger or a vehicle. **DO NOT** place yourself in danger.

25. BE COOL IF YOU CONFRONT A BURGLAR.

If you confront a burglar, play it cool and don't try to stop him. Flee and seek help. Return to your home only after police have arrived. Remember, the reaction of a burglar caught in the act is unpredictable. A few stolen items are a small price to pay when compared to injury to you or your family.

26. DON'T ENTER A BURGLARIZED HOME.

If you discover your home has been burglarized, call the police immediately from your cell phone or a neighbor's home. Don't touch anything. Cooperate with the investigator in every way possible so that a thorough investigation can be made and the burglar can be apprehended.

27. HARDEN THE BURGLAR'S TARGET.

Follow these tips and target-hardening suggestions by giving your home a security survey. If you need any additional information on security hardware, contact the Lower Merion Police Department's CRIME PREVENTION UNIT at 610-645-6240 or your local locksmith.

Begin your home security check with the front door and work clockwise around the entire inside of the house. Include all doors and windows, finishing with the backyard, fence, and shrubs, gates and garage.

Minimum security means the prevention of entry through any door or window except by means of destructive force. (Most burglars will not break a window to enter.)

Additional security means the prevention of exit by an intruder through any door except by means of destructive force. This reduces the possibility of theft or large household possessions, because most burglars will not want to break a door to get out.

The majority of the devices in this booklet cost very little and the home security procedures suggested cost nothing; all of them will help reduce burglary.

DOORS

When considering door security, bear in mind that the rear door is just as important as the front door, and the condition of your door and its frame are just as important as the lock on it. Check your doors for the following:

- **Is the door solidly constructed?** Solid wood or metal doors offer greater security than glass panel or inset wooden panel doors. Hollow core doors offer almost no security.
- **Does the door fit the frame well or is it too loose?** Clearance should be no more than 1/16 inch.
- **Can you see your visitor without opening the door?** If not, install an inexpensive wide angle viewer.
- **Are exposed hinges protected to prevent hinge-pin removal?** Many hardware stores and locksmiths sell pinned



hinges or hinges containing set-screws to prevent pin removal.

Existing hinges may be protected by the following steps:

- Remove two screws opposite each other from both leaves of your hinge.
- Insert screw or concrete nail into jamb leaf, protruding 1/2 inch.
- Drill out the opposing screw hole in the door. Do this in the top and bottom hinge of the door. When the door is closed, the pins may be removed, but the door will remain firmly in place.

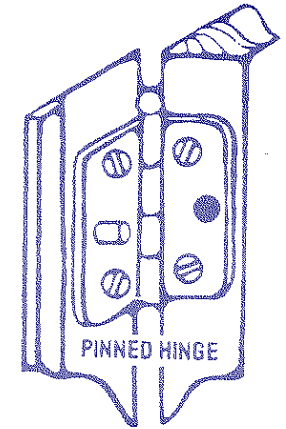

SLIDING DOORS

Sliding glass doors offer the burglar an easy way to enter your home. The purpose of securing a sliding door is to keep it from sliding or being pried up and out of the track when locked.

The stationary part of the door system must be permanently secured in place. Do this by drilling through the frame and door and inserting a self tapping metal screw through the frame and into the door. Screws must be inserted from the inside of the home. Many stationary doors are secured by the builder upon installation; however, this must be verified as a first precaution.

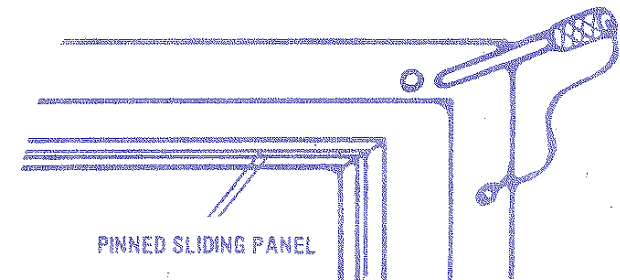

The sliding (free moving) door must be secured in place (when locked).